

III B. Tech I Semester Regular Examinations, November - 2015
DYNAMICS OF MACHINERY
 (Common to ME and AME)

Time: 3 hours

Max. Marks: 70

- Note: 1. Question Paper consists of two parts (**Part-A** and **Part-B**)
 2. Answering the question in **Part-A** is compulsory
 3. Answer any **THREE** Questions from **Part-B**

PART -A

- | | | |
|---|---|------|
| 1 | a) What is gyroscopic torque? | [4M] |
| | b) What is meant by expression friction circle? | [4M] |
| | c) What is meant by turning moment diagram or crank effort diagram? | [4M] |
| | d) What is the function of governor? | [4M] |
| | e) What is meant by balancing of rotating masses? | [3M] |
| | f) What are the causes and effect of vibration? | [3M] |

PART -B

- 2 The turbine rotor of a ship has a mass of 20 tones and a radius of gyration 0.75. Its speed is 2000 rpm. The ship pitches 6° above and below the horizontal position .One complete oscillation takes 18 seconds and the motion is simple harmonic. Determine [16M]
- (i) the maximum couple tending to shear the holding down bolt of the turbine
- (ii) The maximum angular acceleration of the ship during pitching. The direction in which the bow will tend to turn while, if the rotation of the rotor is clockwise when looking from rear.
- 3 a) Which of the two assumptions-uniform intensity of pressure or uniform rate of wear, would you make use of in designing friction clutch and why? [8M]
- b) A cone clutch with cone angle 20° is to transmit 7.5 kW at 750 rpm. The normal intensity of pressure between the contact faces is not to exceed 0.12N/mm^2 . The coefficient of friction is 0.2. If face width is $1/5^{\text{th}}$ of mean diameter, find: [8M]
- (i) The main dimensions of the clutch and
- (ii) Axial force required while running.
- 4 The turning moment diagram for a four stroke gas engine may be assumed for simplicity to be represented by four triangles, the areas of which from the line of zero pressure are as follows: Expansion stroke = 3550 mm^2 ; Exhaust stroke = 500 mm^2 ; Suction stroke = 350 mm^2 ; and compression stroke = 1400 mm^2 . each mm^2 represents 3 N-m. Assuming the resisting moment to be uniform, find the mass of the rim of a fly wheel required to keep the mean speed 200 rpm within $\pm 2\%$. The mean radius of the rim may be taken as 0.75 m. Also determine the crank positions for the maximum and minimum speeds. [16M]



- 5 The lengths of the upper and lower arms of a porter governor are 200mm and 250mm respectively. Both the arms are pivoted on the axis of rotation. The central load is 150N, the weight of the each ball is 20N and the friction of the sleeve together with the resistance of the operating gear is equivalent to a force of 30N at the sleeve. If the limiting inclinations of the upper arms to the vertical are 30° and 40° taking friction in to account. Find the range of speed of the governor. [16M]
- 6 Four masses M_1 , M_2 , M_3 and M_4 are 200kg, 300kg, 240kg and 260kg respectively. The corresponding radii of rotation are 0.2m, 0.15m, 0.25m and 0.3m respectively and the angle between successive masses are 45° , 75° and 135° . Find the position and magnitude of balance mass required if its radius of rotation is 0.25m. [16M]
- 7 In a single degree of damped vibration system a suspended mass of 8kg makes 30 oscillations in 18 seconds. The amplitude decreases in 18 seconds. The amplitude decreases to 0.25 of the initial value after 5 oscillations. Determine
- the spring stiffness
 - logarithmic decrement
 - damping factor
 - Damping coefficient.

(4M+4M+4M+4M)

-000-

III B. Tech I Semester Regular Examinations, November - 2015
DYNAMICS OF MACHINERY
 (Common to ME and AME)

Time: 3 hours

Max. Marks: 70

- Note: 1. Question Paper consists of two parts (**Part-A** and **Part-B**)
 2. Answering the question in **Part-A** is compulsory
 3. Answer any **THREE** Questions from **Part-B**

PART -A

- | | | |
|---|--|------|
| 1 | a) What is the effect of gyroscopic couple on rolling of ship? Why? | [4M] |
| | b) What is friction? Is it a blessing or curse? Justify your answer giving examples? | [4M] |
| | c) Why flywheels are needed in forging and pressing operations? | [4M] |
| | d) How governors are classified? | [4M] |
| | e) Why rotating masses are to be dynamically balanced? | [3M] |
| | f) Define frequency, cycle, period and free vibration. | [3M] |

PART -B

- | | | |
|---|---|--------------|
| 2 | The rotor of a turbine yacht rotates at 1200rpm clockwise when viewed from stern. The rotor has a mass of 750 kg and radius of gyration of 250mm. Find the maximum gyroscopic couple transmitted to the hull when yacht pitches with a maximum angular velocity of 1 rad/s. What is the effect of this couple? | [16M] |
| 3 | A band and block brake having 12 blocks, each of which subtends an angle of 160 at the centre, is applied to a rotating drum of diameter 600 mm. the blocks are 75 mm thick. The drum and the flywheel mounted on the same shaft have a mass of 1800kg and have a combined radius of gyration of 600mm. the two ends of the band are attached to pins on the opposite sides of the brake fulcrum at distance of 40 mm and 150mm from the fulcrum. If a force of 250 N is applied at a distance of 900 mm from the fulcrum, find (i) the maximum braking torque (ii) the angular retardation of the drum (iii) the time taken by the system to be stationary from the rated speed of 300 rpm. Take coefficient of friction between the blocks and the drum as 0.3. | [16M] |
| 4 | Derive expression for
(a) Coefficient of steadiness
(b) Energy stored in flywheel. | [8M]
[8M] |
| 5 | A porter governor has equal arms each 250mm long and pivoted on the axis of rotation. Each ball has a mass of 5kg and mass of the central load on the sleeve is 25kg. The radius of rotation of the ball is 150mm when governor is at maximum speed. Find the maximum and minimum speed and range of speed of the governor | [16M] |
| 6 | Four masses A, B, C and D revolves at equal radii and equally spaced along a shaft. The mass B is 7kg and the radii of C and D make angle s of 90° and 240° respectively with the radius of B. Find the Magnitude of masses A, C and D and angular position of A, so that the system may be completely balanced. | [16M] |
| 7 | Derive an expression for the natural frequency of the free longitudinal vibration by
(i) Equilibrium method, (ii) Energy method, (iii) Rayleigh's method. | [16M] |

-000-



III B. Tech I Semester Regular Examinations, November - 2015
DYNAMICS OF MACHINERY
 (Common to ME and AME)

Time: 3 hours

Max. Marks: 70

- Note: 1. Question Paper consists of two parts (**Part-A** and **Part-B**)
 2. Answering the question in **Part-A** is compulsory
 3. Answer any **THREE** Questions from **Part-B**

PART -A

- | | | |
|---|---|------|
| 1 | a) Define gyroscopic couple | [4M] |
| | b) Explain the terms: friction circle and friction axis | [4M] |
| | c) Differentiate the function of flywheel and governor | [4M] |
| | d) Differentiate between governor and fly wheel | [4M] |
| | e) Define static balancing. | [3M] |
| | f) What are the different types of vibrations? | [3M] |

PART -B

- | | | |
|---|---|-------|
| 2 | Each paddle wheel of a steamer has a mass of 1600kg and a radius of gyration of 1.2m. The steamer turns to port in a circle of 160m radius at 24Km/hr. The speed of the paddle is 90 rpm. Find the magnitude and effect of the gyroscopic couple acting on the steamer. | [16M] |
| 3 | a) Describe with a neat sketch the working of a single plate friction clutch. | [8M] |
| | b) Establish a formula for the maximum torque transmitted by a single plate clutch of external and internal radii r_1 and r_2 , if the limiting coefficient of friction is μ and the axial spring load is W . Assume that the pressure intensity on the contact faces is uniform. | [8M] |
| 4 | a) What is meant by piston effort and crank effort? | [8M] |
| | b) The crank of a three-cylinder single-acting engine is set equally at 120° the engine speed is 540 rpm. The turning-moment diagram for each cylinder is a triangle for the power stroke with a maximum torque of 100 N-m at 60° after dead- centre of the corresponding crank. On the return stroke, the torque is sensibly zero. Determine | [8M] |
| | (i) The power developed | |
| | (ii) The coefficient of fluctuation of speed if the flywheel has a mass of 7.5 kg with a radius of gyration of 65 mm | |
| | (iii) The coefficient of fluctuation of energy and | |
| | (iv) The maximum angular acceleration of the fly wheel. | |
| 5 | A hartnell governor having a central sleeve spring and two right angled bell crank lever operates between 290rpm and 310rpm for a sleeve lift of 15mm. The sleeve and ball arms are 80mm and 120mm respectively. The levers are pivoted at 120mm from the governor axis and mass of the ball is 2.5kg. The ball arms are parallel at lowest equilibrium speed. Determine (i) load on the spring at maximum and minimum speeds and (ii) Stiffness of the spring. | [16M] |



- 6 Derive the following expression of effects of partial balancing in two cylinder locomotive engine (i) Variation of tractive force, (ii) Swaying couple and (iii) Hammer blow. [16M]
- 7 a) A cantilever shaft 50mm diameter and 300mm long has a disc of mass 100kg at its free end. The Young's modulus for the shaft material is 200GN/m^2 . Determine the frequency of longitudinal and transverse vibration of the shaft. [8M]
- b) Explain, with sketches the different cases of damped vibrations. [8M]

-000-



III B. Tech I Semester Regular Examinations, November - 2015
DYNAMICS OF MACHINERY
 (Common to ME and AME)

Time: 3 hours

Max. Marks: 70

- Note: 1. Question Paper consists of two parts (**Part-A** and **Part-B**)
 2. Answering the question in **Part-A** is compulsory
 3. Answer any **THREE** Questions from **Part-B**

PART -A

- 1 a) Write expression for gyroscopic couple. [4M]
- b) What is meant by uniform pressure theory or uniform wear theory for the friction torque of a bearing? [4M]
- c) List out the few machines in which flywheel are used. [4M]
- d) What is meant by sensitiveness of a governor? [4M]
- e) Define dynamic balancing [3M]
- f) State different methods of finding natural frequency of a system. [3M]

PART -B

- 2 a) Explain the effect of Gyroscopic couple on a Naval ship during pitching. [8M]
- b) Explain the effect of Gyroscopic couple on a Aeroplane. [8M]
- 3 a) A truncated conical pivot of cone angle ϕ rotating at speed N supports a load W. The smallest and largest diameter of pivot over the contact area 'd' and 'D' respectively. Assuming uniform wear, derive the expression for frictional torque. [8M]
- b) A differential band brake, as shown in figure, below has an angle of contact of 225° . The band has a compressed woven lining and bears against a cast iron drum of 350 mm diameter. The brake is to sustain a torque of 350 N-m and the coefficient of friction between the band and the drum is 0.3. Find i) The necessary force (P) for the clockwise and anticlockwise rotation of the drum; and ii) The value of 'OA' for the brake to be self locking, when the drum rotates clockwise. [8M]

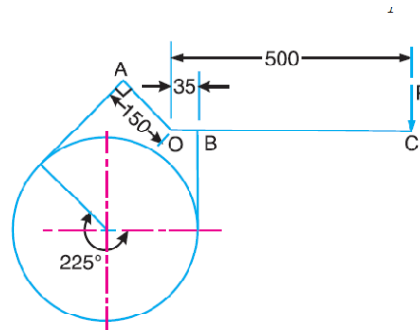

All dimensions in mm.



- 4 What is the function of a flywheel? How does it differ from that of a governor? [16M]
The torque delivered by a two –stroke engine is represented by $t = (1000 + 300 \sin 2\phi - 500 \cos 2\phi)$ N. m where ϕ is the angle turned by the crank from the inner-dead centre. The engine speed is 250 rpm. The mass of the flywheel is 400 kg and radius of gyration is 400 mm. Determine (i) The power developed (ii) The total percentage fluctuation of speed (iii) The angular acceleration of flywheel when the crank has rotated through an angle of 60° from the inner-dead centre and (iv) The maximum angular acceleration and retardation of the flywheel.
- 5 Calculate the rage of speed of a porter governor which has equal arms of each 200mm long and pivoted on the axis of rotation. The mass of each ball is 4kg and the central load of the sleeve is 20kg. The radius of rotation of the ball is 100mm when the governor being to lift and 130mm when the governor is at maximum speed. [16M]
- 6 The data for three rotating masses are given below: [16M]

$M_1 = 4\text{kg}$	$r_1 = 75\text{mm}$	$\theta_1 = 45$
$M_2 = 3\text{kg}$	$r_2 = 85\text{mm}$	$\theta_2 = 135$
$M_3 = 2.5\text{kg}$	$r_3 = 50\text{mm}$	$\theta_3 = 240$

Determine the amount of counter mass at a radial distance of 65mm required for their static balance.
- 7 A steel shaft 100mm in diameter is loaded and support in shaft bearing 0.4m apart. The shaft carries three loads: first mass 12kg at the centre, second mass 10kg at a distance 0.12m from the left bearing and third mass of 7kg at a distance 0.09m from the right bearing. Find the value of the critical speed by using Dunker ley's method if $E = 2 \times 10^{11} \text{N/m}^2$. [16M]

-000-

